

REF :

MG/102

MANUFACTURER : SMAG

**MACH GLOBAL**  
PRINTING SOLUTIONS

**SMAG X**  
SMART SOLUTIONS



**Stéphane Rateau**

Managing Director

MACHGLOBAL SAS

Paris (France)

+33(0)609041028



Connect with me



My digital business card

GALAXIE MONO (Year 2019)

EXCELLENT CONDITION

- . Unwinder,
- . Screen printing station with UV dryer,
- . Central feeding servo station,
- . Slitter, Waste rewinder and dual rewinding shafts.

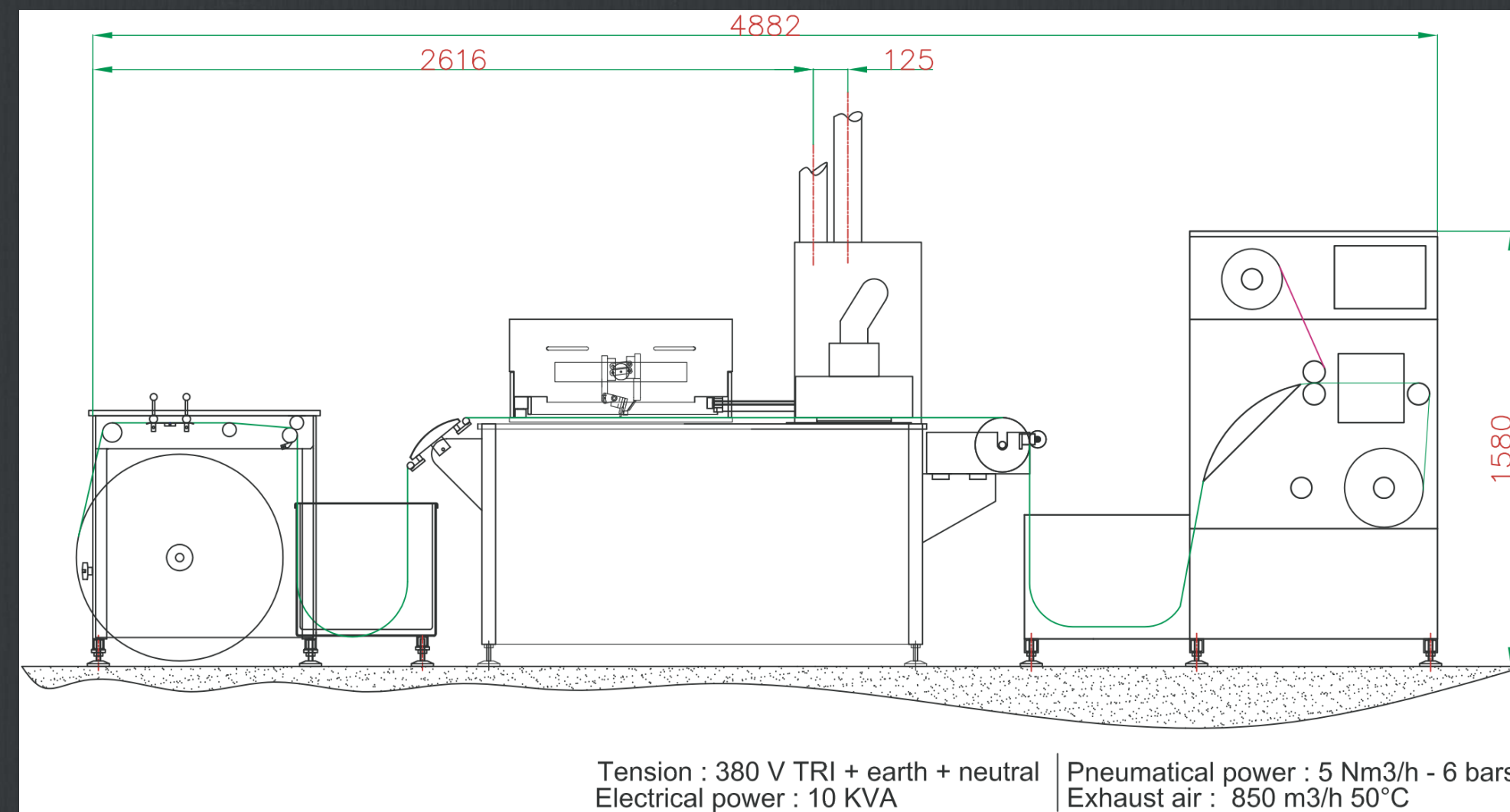

Working flow : from left to right  
 Number of printing stations : 1  
 Max web width : 260 mm  
 Max working area : 250 mm x 250 mm  
 Max. roll diameter (unwinder) : 750 mm  
 Max. roll diameter (rewinder) : 500 mm  
 Feeding servo precision (according to the type of substrate) +/- 0,1 mm  
 Speed (according to printing stroke) : 2200 IPH with a stroke of 250 mm

# Prices and terms :

---

- ▶ PRICES:
  - ▶ 45 000 Euros final user price
  - ▶ Terms of transportation : Ex Works SMAG-X factory with truck transportation packing
- ▶ Terms of installation : not included and as option
- ▶ Terms of payment : 30% at the order, 60% after take over and before shipment, 10% after installation.
- ▶ Terms of warranty : 6 months on parts // Revised by SMAG-X
- ▶ Available at SMAG-X for FAT December 2025